

Fig 15 ... junction with pre-formed double-lock cross welt

This detail is mainly for use in Traditional roofing because it allows no longitudinal movement. However, it is sometimes used in Long Strip roofing where the form of the roof requires a transition from a straight to a curved section (see Fig 15b).

It can also be used in Long Strip if the appearance of cross welts is required. In this case, from the point of view of acceptable bay sizes, the presence of the cross welts is ignored; and lateral joints for movement must be provided, or overall bay sizes limited, in accordance with Table L. Sliding clips, of course, must also be provided as shown on Table L (p11).

When pre-patinated copper sheets have been specified, it is better to use this pre-formed cross welt as some of the patina will be lost in the hand-forming (see Fig 15a). The pre-formed version also tends to give cleaner lines.

In both Traditional and Long Strip roofing, the double-lock cross welt can only be used with roof pitches at and over 20degrees. If sealed they can be used with roof pitches down to 6degrees.

Temper: quarter- or half-hard copper must be used, as no clip is possible at centre of bay.  
Thickness: 0.6mm or 0.7mm

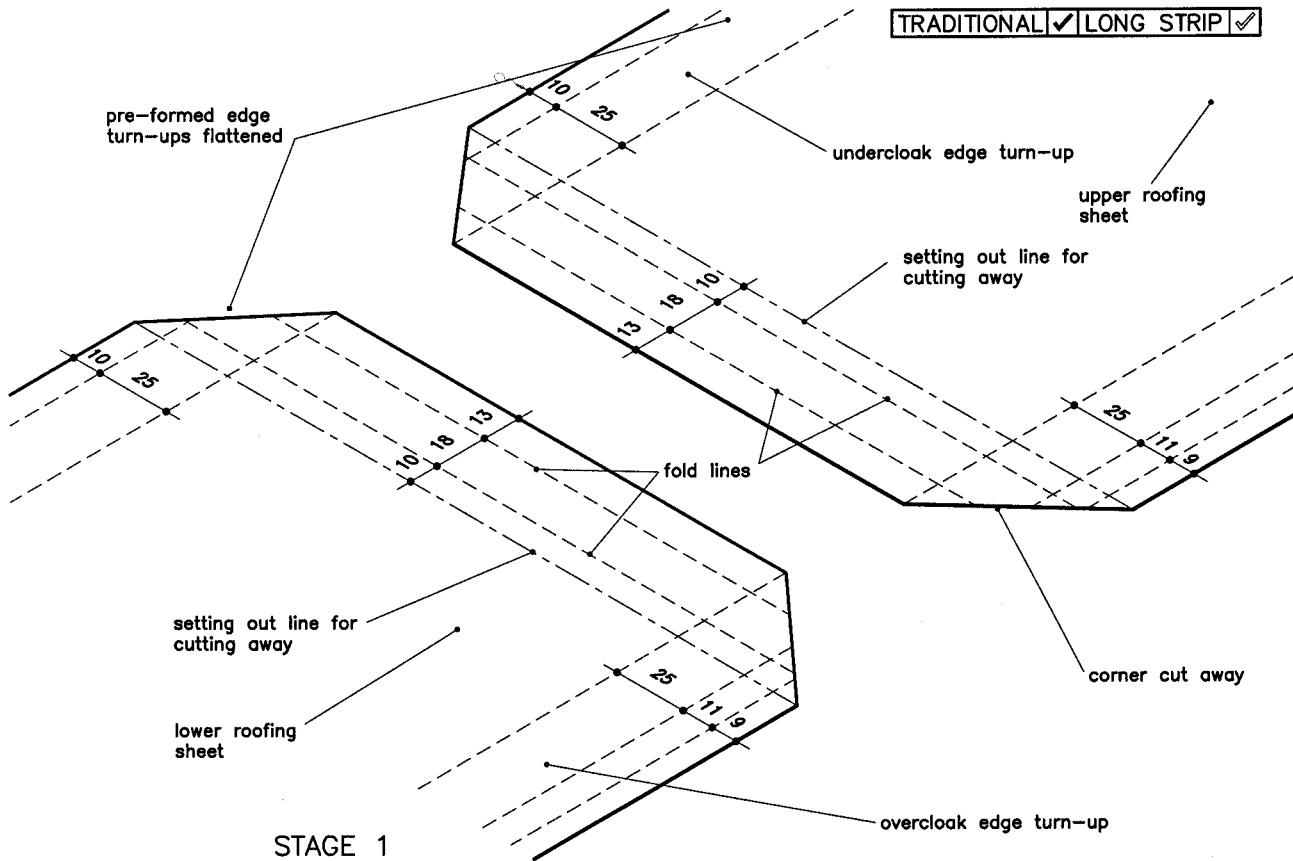

**Stage 1**

Flatten pre-formed edge turn-ups (see Fig 14) of overcloak and undercloak at the ends of the sheets or trays to be joined, to allow marking out and cutting.

Cut away the corners to reduce the bulk of copper layers that will occur otherwise at the intersection with the standing seam. Use straight snips for cutting.

Form open double-lock welts along fold lines, to the ends of both sheets. This can be done with a special folding machine or by bending the copper around a 4mm thick aluminium section.

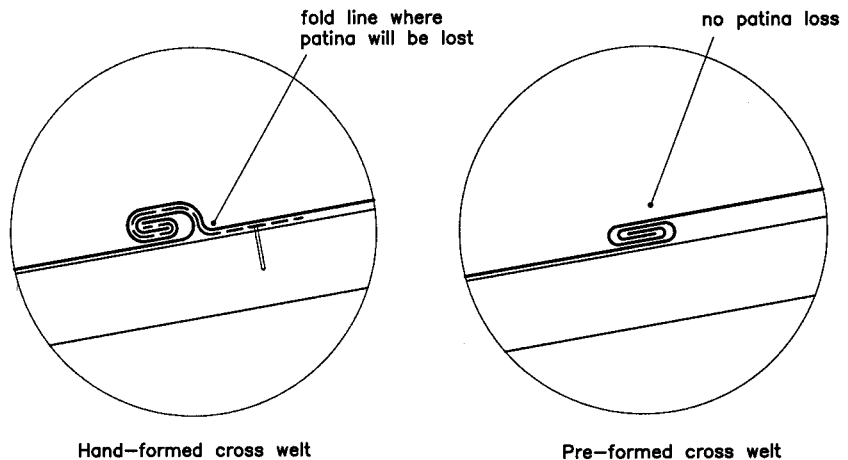

Fig 15a  
Cross welt for pre-patinated sheet

TRADITIONAL ✓ LONG STRIP ✓

Stage 2  
Slide the open welts together and adjust the sheets until they line up.

Dress seam down flat to the surface of the substrate to complete the joint. To make provision for bringing the standing seams upright neatly, it will be necessary to indent the cross welt at the folding point with the blade head of a hammer, to start the fold.

Reform the edge turn-ups flattened for Stage 1 and complete the double-lock standing seams (see Figs 1 and 2).

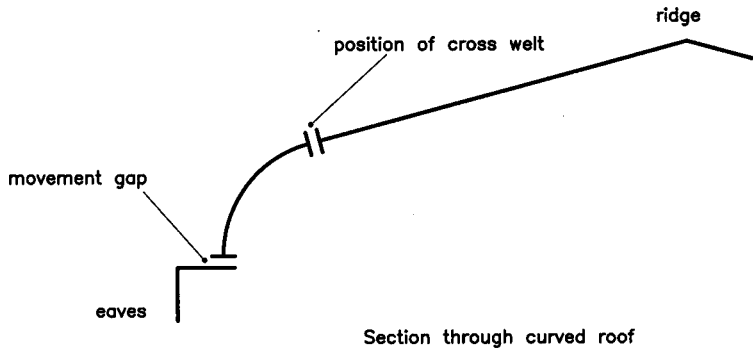
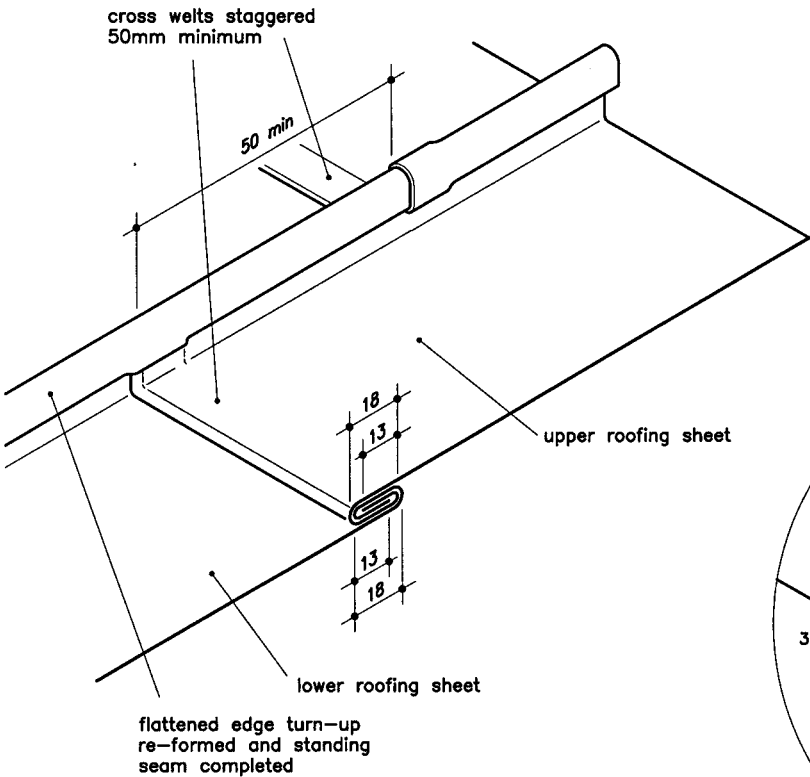
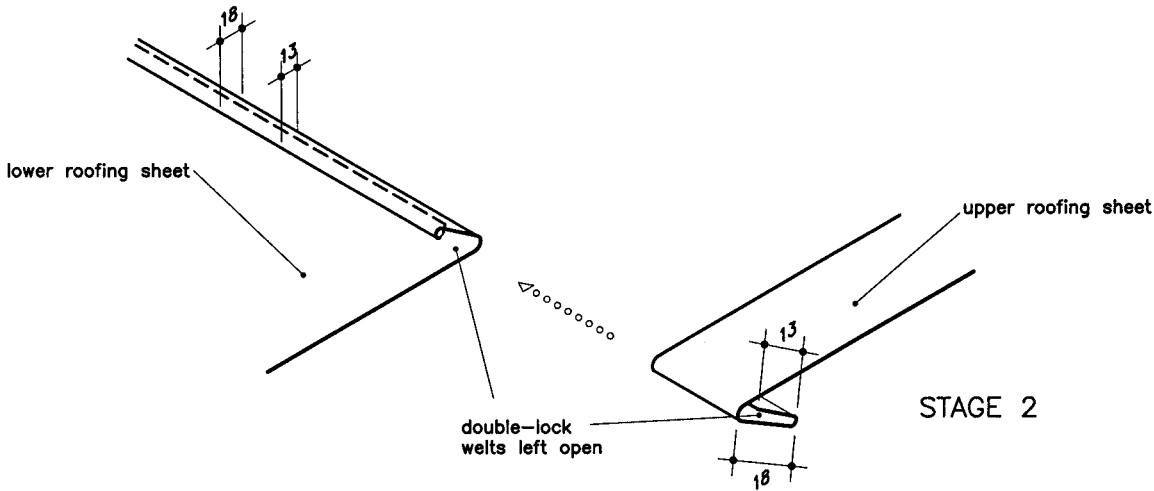

Fig 15b  
Cross welt as transition from straight to curved tray  
TRADITIONAL ✓ LONG STRIP ✓



STAGE 3

Stage 3  
The cross welt is complete.

