

Fig 18 Double-lock standing seam at external corners

This detail uses a sweep type detail called the 'graduated standing seam'. The undercloak is formed as the Sweep standing seam upstand (see Fig 7), using curved cutting and a dog-ear fold to achieve the sweep. The overcloak has no folding but is simply cut from the sheet with the shape of the curve. This is then folded over the undercloak to make a double-lock standing seam in the usual way.

The run of the seam is kept to a minimum, say 450mm down from the abutment, by introducing a double-lock cross welt (see Figs 14 and 15). This is for two reasons. Firstly, the seam has to be folded over to retain the return upstand against the abutment, thus restricting lateral movement. Secondly, it reduces the wastage that results from the cutting away of the sheet edges, necessary to form the sweep.

The abutment corner with its graduated standing seam affects the spacing of the adjacent bays. The layout of the bays, therefore, needs to be thought out beforehand. Refer to Tables E (p8) and J (p10) for bay widths. Forming the seam takes up about 125mm.

In Long Strip roofing, the Pinched seam upstand (see Figs 8 and 12) is used where the other standing seams meet the general run of the abutment. The cover flashing detail (see Fig 12a) needs to allow 10mm for longitudinal movement.

In Traditional roofing, the Sweep standing seam upstand (see Fig 7) or the Turned-down seam upstand (see Fig 11) is used where the other standing seams meet the general run of the abutment. In both cases the seam is folded flat against the abutment. For cover flashing details see Figs 11a, 11b, 11c (p46) and 12b (p48). Stepped cover flashings are shown in Figs 18a, 18b and 18c (p59).

Temper: Roofing sheet; easier in soft or quarter-hard, but can be done in half-hard. Pre-formed cover flashing etc; half-hard.

Thickness: 0.6mm or 0.7mm

TRADITIONAL LONG STRIP

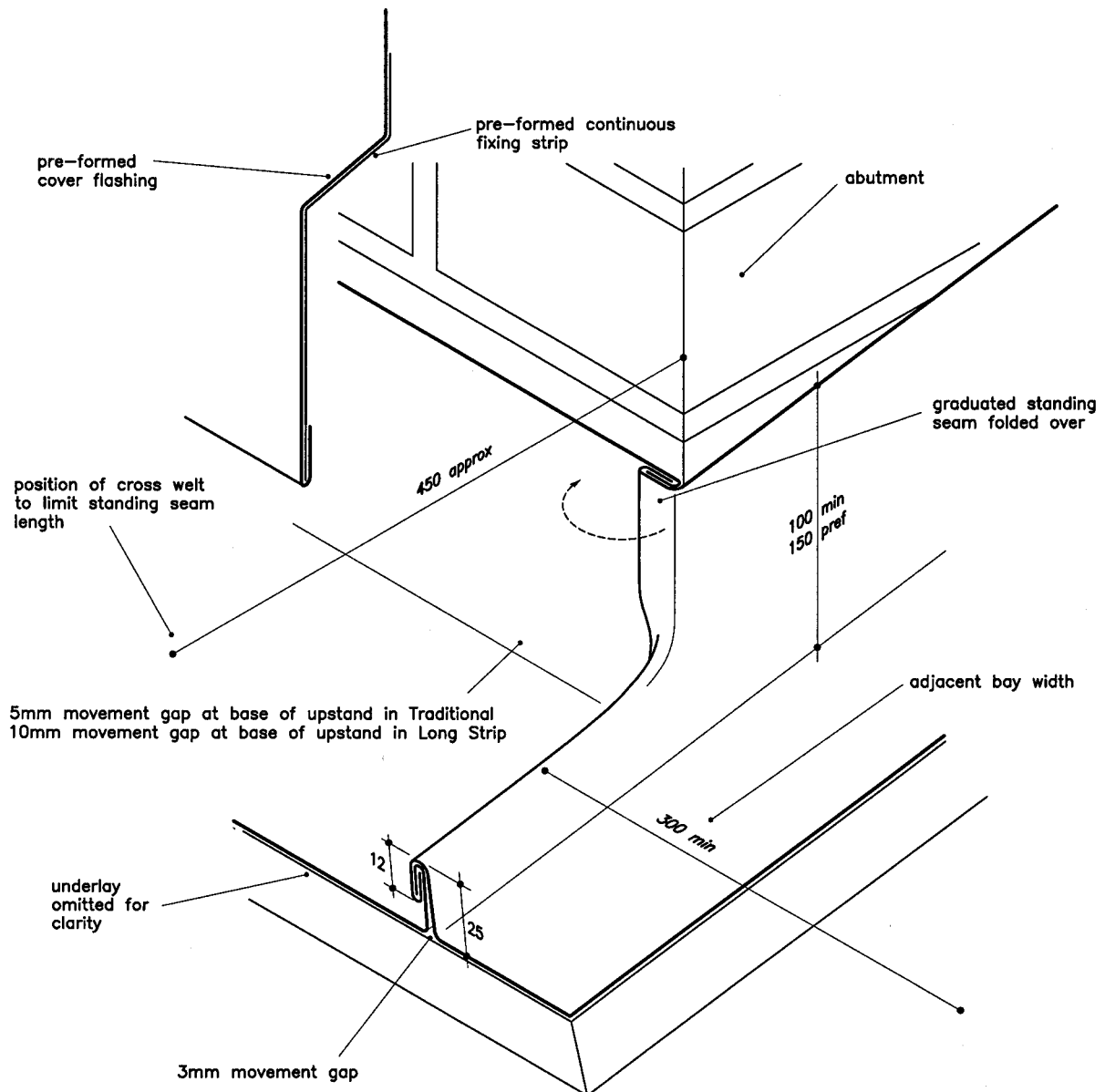

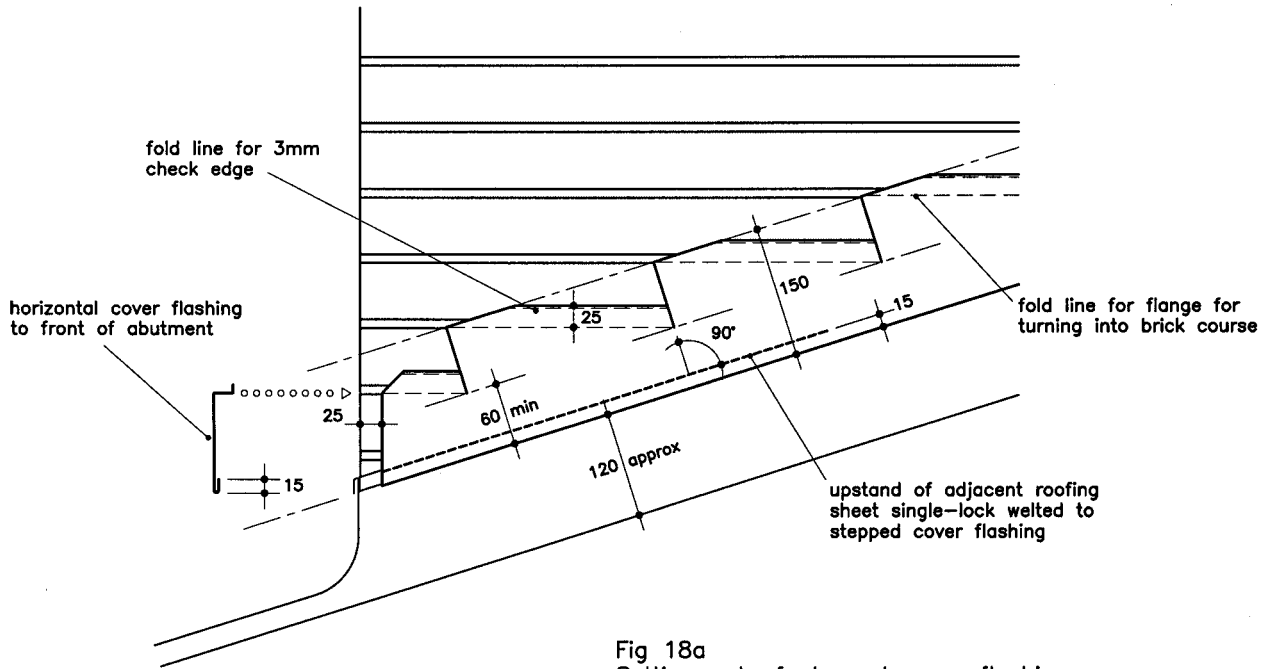

Fig 18a
Setting out of stepped cover flashing

TRADITIONAL ✓ LONG STRIP ✓

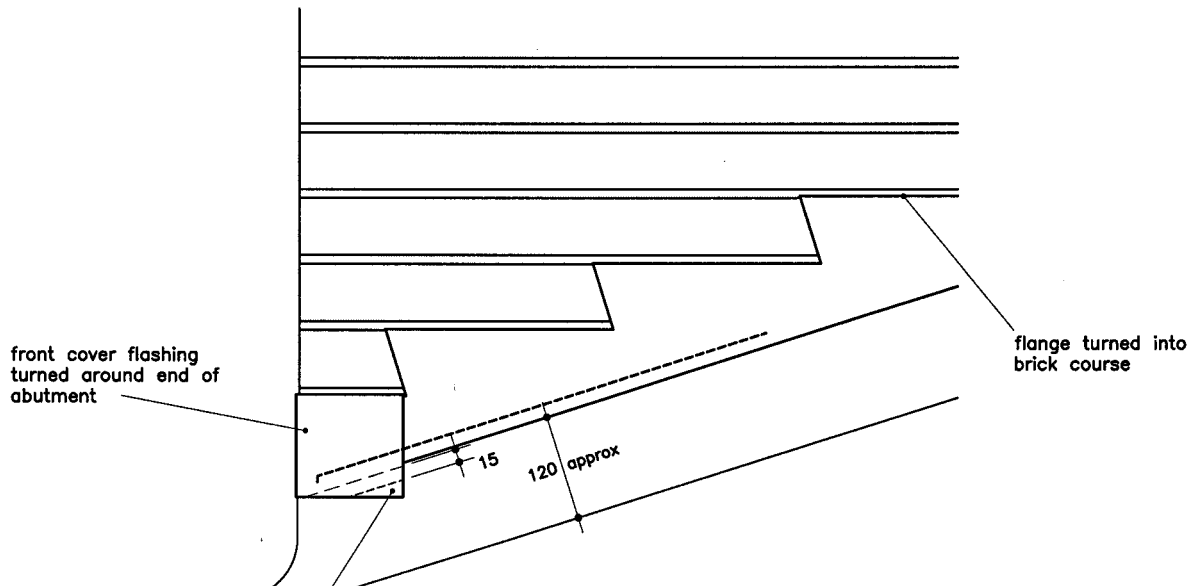

Fig 18b
Stepped cover flashing Elevation

TRADITIONAL ✓ LONG STRIP ✓

trim corner off cover flashing to welt into stepped cover flashing

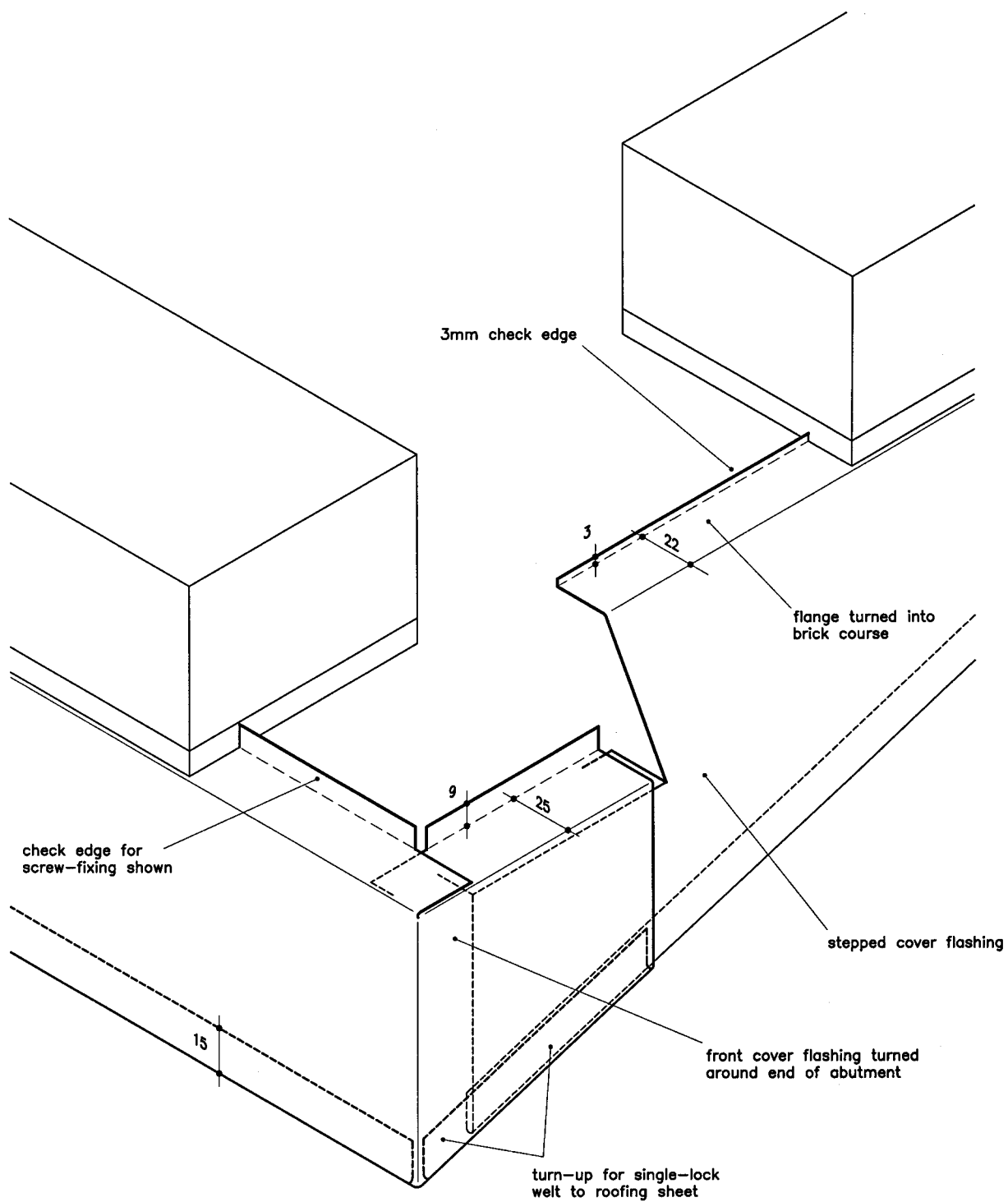

Fig 18c
Stepped cover flashing junction with horizontal flashing

TRADITIONAL ✓ LONG STRIP ✓