

Fig 2 Roll-formed profiled trays

This is the most efficient method of forming standing seams and is therefore used wherever possible. It gives a very consistent and precise appearance to the seam. As seaming machines can work up to the vertical, this quality can be achieved in cladding as well as roofing.

For cladding, horizontal seams are also possible (see Fig 24a) with, of course, the welt turned to the underside of the seam. The 'angle standing seam', which is simply with the seam completed at Stage 2, is often used in cladding because there tends to be less localised distortion or quilting effect to the copper sheet.

In roofing its minimum pitch unsealed is 6degrees. With a closed cell sealing strip such as Illmod, pitches down to 3degrees are possible, depending on exposure. Whether to seal or not should be discussed with the copper roofer. The angle standing seam can only be used at and over 25degrees roof pitch.

For bay widths taken from seam centre to seam centre, see Table E (p8) and J (p10). Also see Tables M and N (p12).

Temper: half-hard
Thickness: 0.6mm or 0.7mm

TRADITIONAL ✓ LONG STRIP ✓

Stage 1
Preform tray in the workshop using a profiling machine. This automatically forms the 3mm gap needed to allow for lateral movement in the copper sheet.

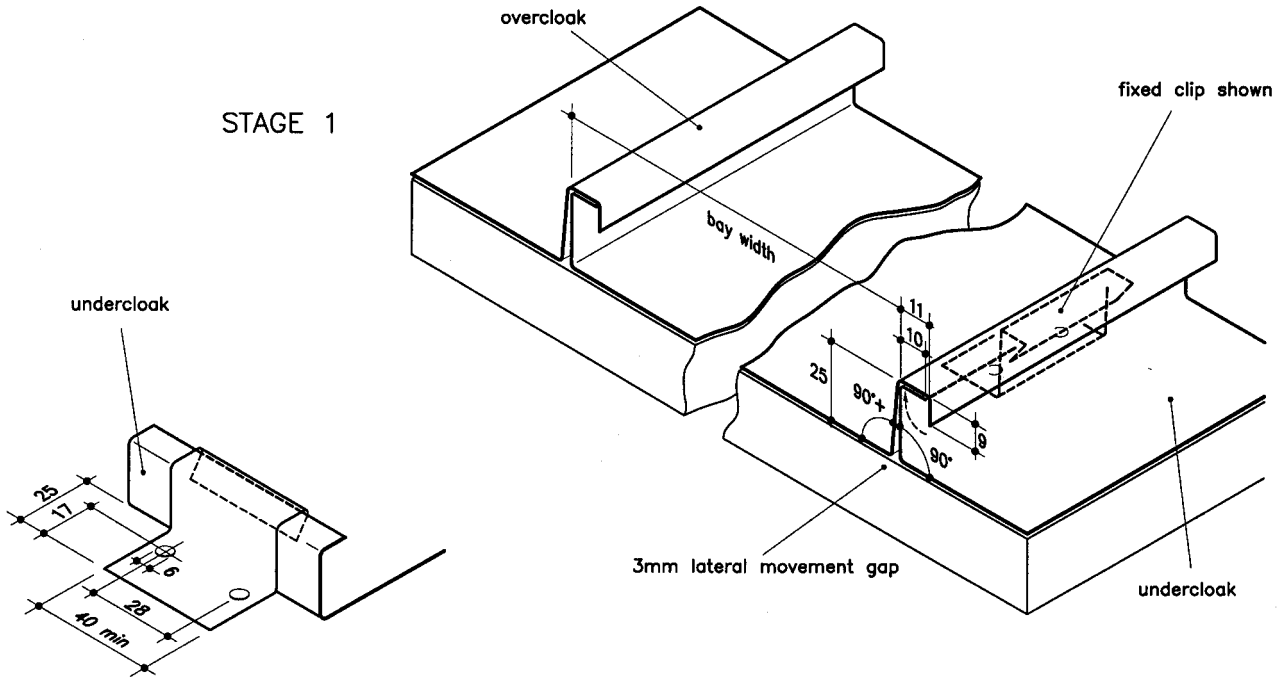

- * Minimum dimensions shown. Clips are more often 50mm wide.
- * In most detail locations clips are spaced at 300mm centres, but see also Table L (p11)

Fig 2b Fixed clip
TRADITIONAL ✓ LONG STRIP ✓

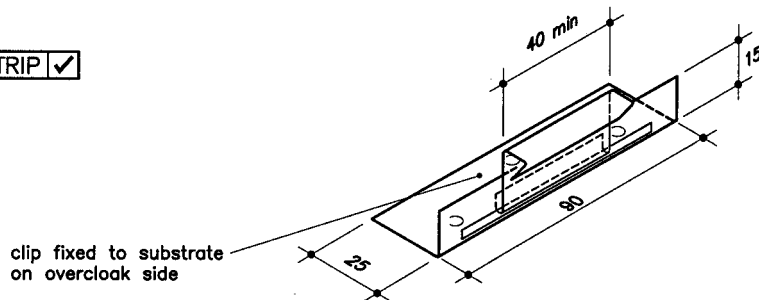

* For spacing and positioning of clips, see Table L (p11).

Fig 2c Sliding clip
TRADITIONAL X LONG STRIP ✓

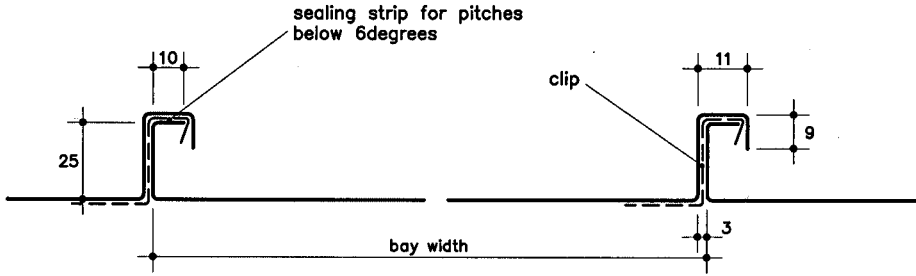
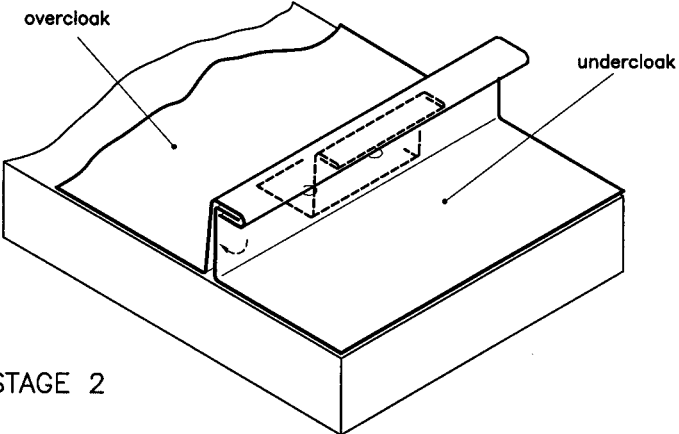

Fig 2a Section across tray
 TRADITIONAL ✓ LONG STRIP ✓



Stage 2
 For Traditional roofing a seaming machine is not possible as it cannot run over the cross welts. Instead a hand-operated angle seamer is used, followed by a double seamer to complete Stage 3.

With Long Strip roofing the bottom 300mm run of the seam is formed using hand-operated seamers. This provides a guide for the seaming machine.

This is the final stage for the Angle standing seam.

STAGE 2

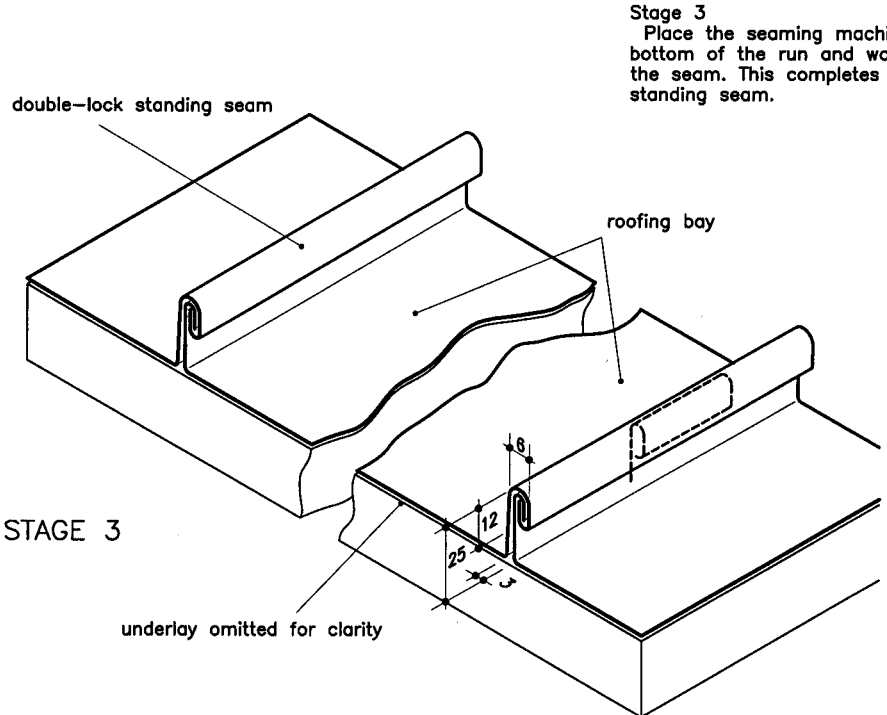

Stage 3
 Place the seaming machine at the bottom of the run and work up the seam. This completes the standing seam.

STAGE 3