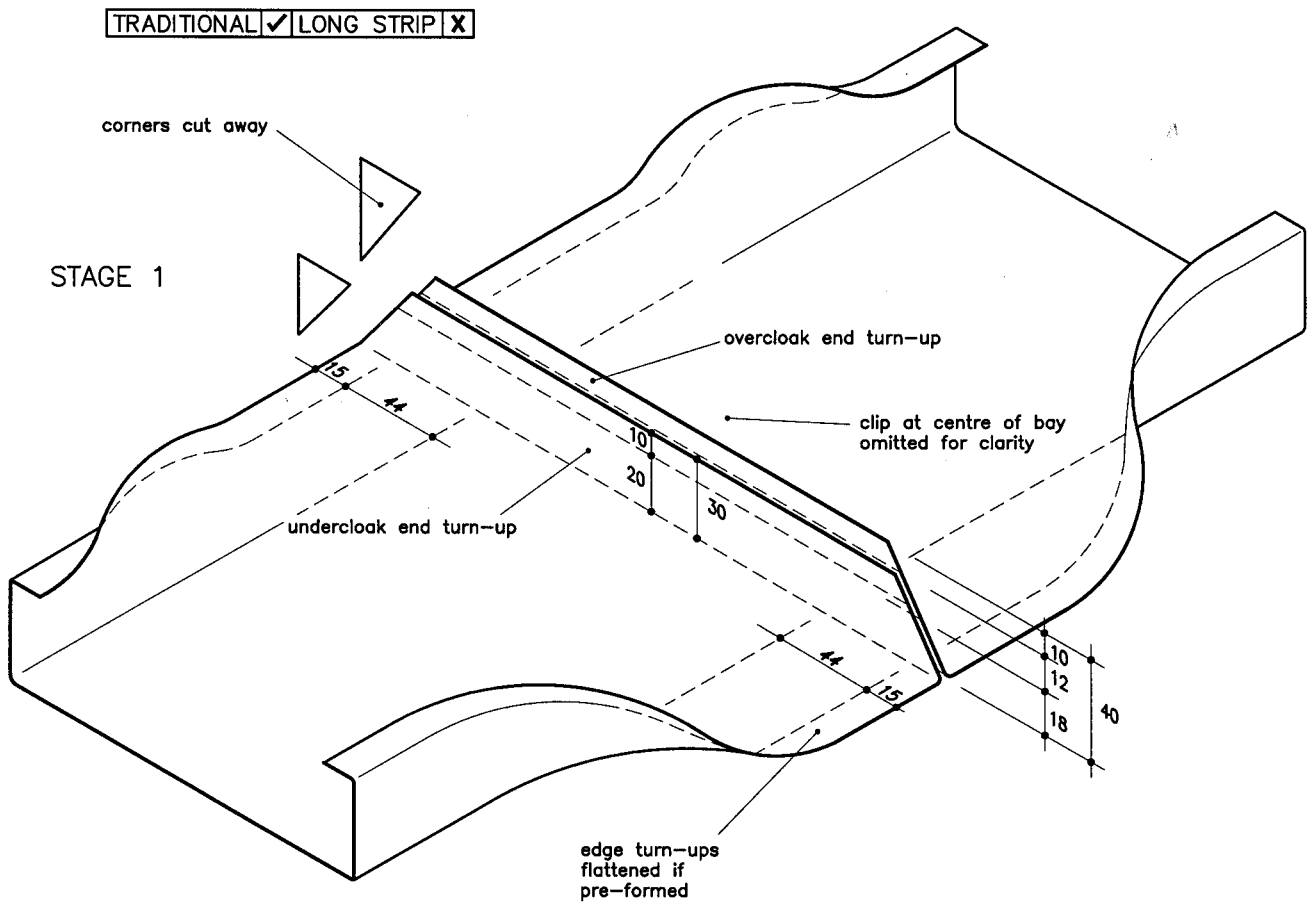
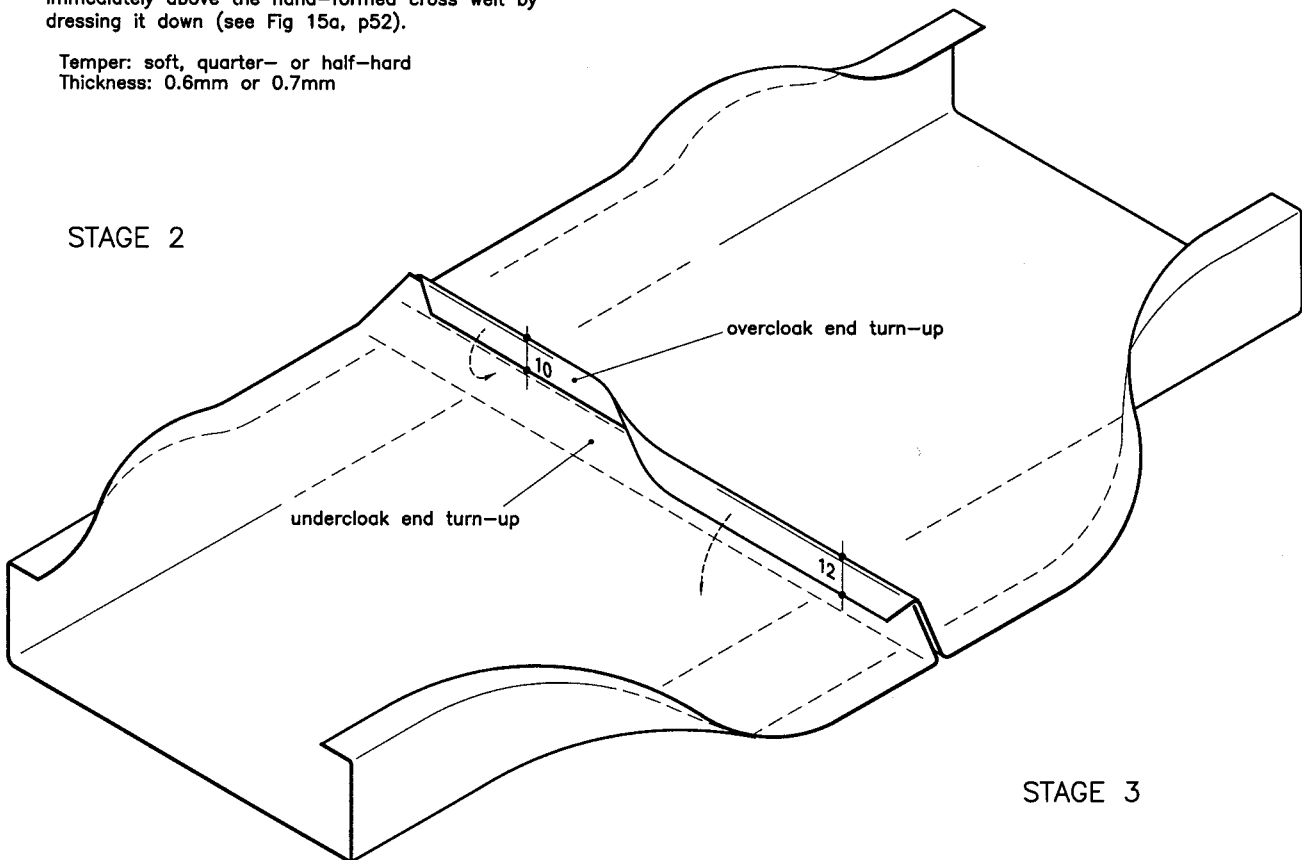

Fig 46 Batten roll junction with hand-formed double-lock cross welt



\* The alternative 'pre-formed cross welt' is shown in Fig 47 (p110). This method avoids the crease formed immediately above the hand-formed cross welt by dressing it down (see Fig 15a, p52).

Temper: soft, quarter- or half-hard  
Thickness: 0.6mm or 0.7mm



STAGE 3

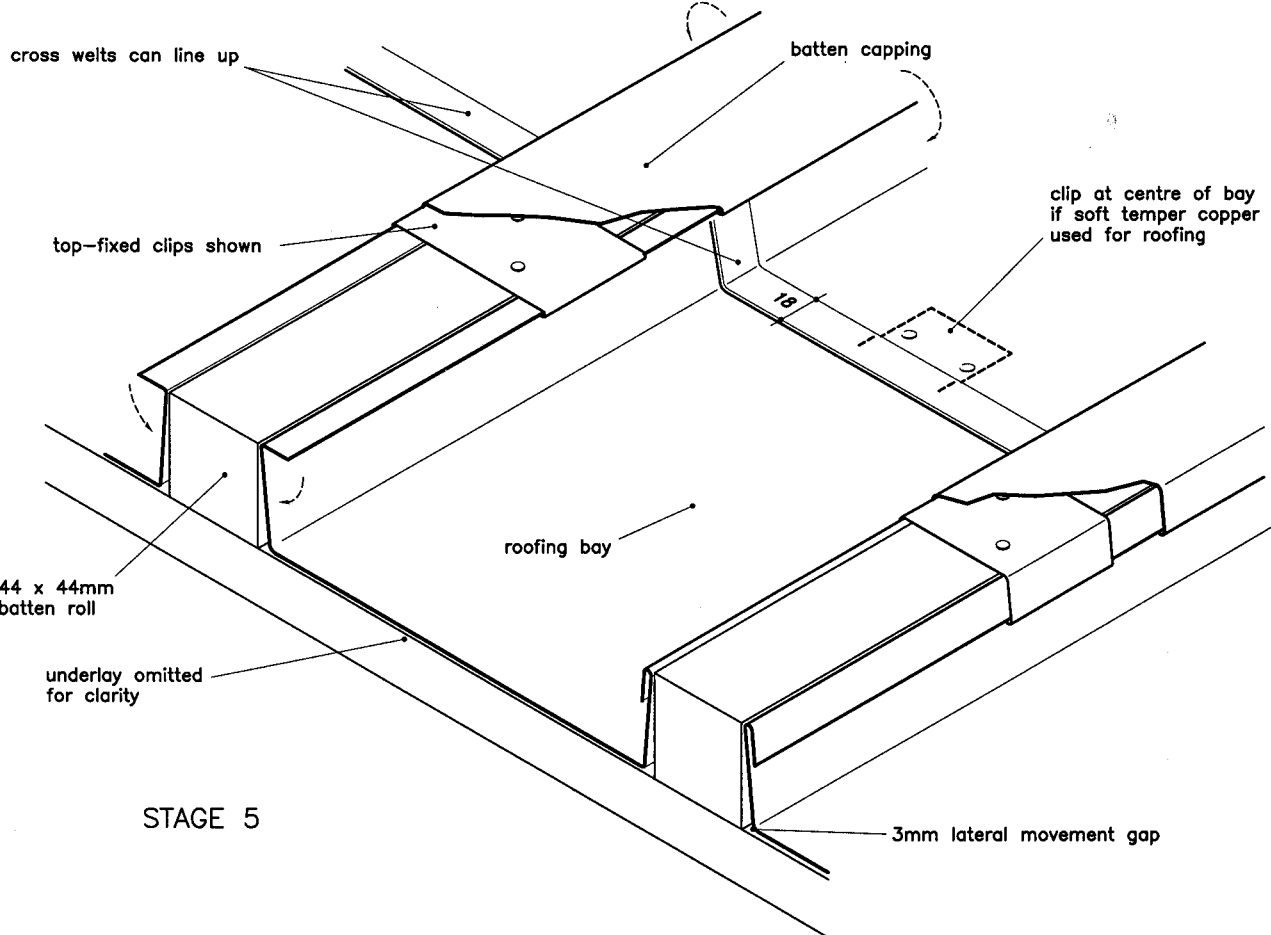

STAGE 5

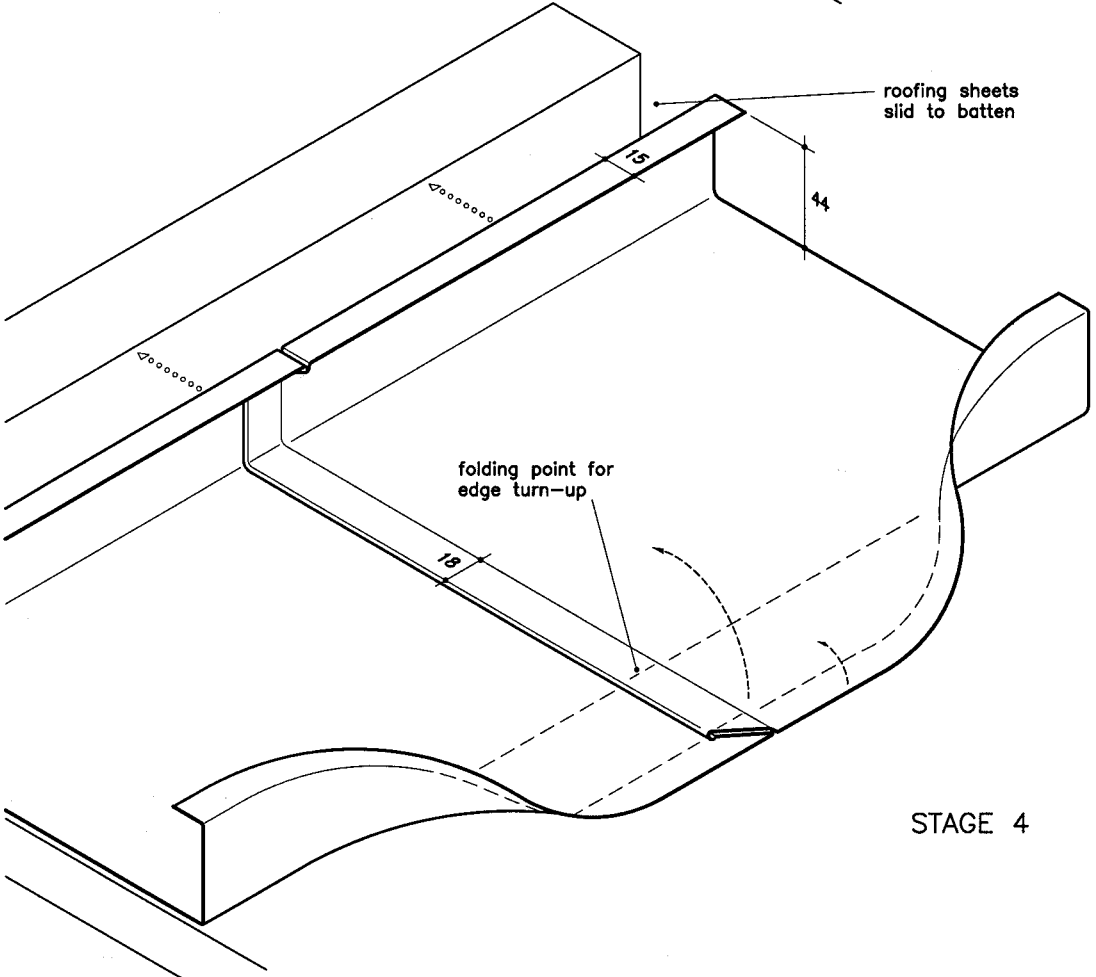

STAGE 4